







Habiins-8/5, Habiins-12



UIC	TWA	Dispo-Gruppe
Habiins	HB 85	D2
Habiins	HB 12	D2

Habiins-8/5, Habiins-12

								
Wagendaten	Wagon data	Caractéristiques techniques	Caratteristiche tecniche	Vagndata	Dane wagonu	Vagon detayları	Habiins-8/5	Habiins-12
Dispo-Gruppe	Order group	Code groupe	Gruppo Dispo	Dispogrupp	Typ wagonu	Vagon Grubu		
Profil	Gauge	Gabarit	Profilo	Profil	Profil	Gabari	G 2	G 2
Wagenlänge über Puffer	Overall length over buffers	Longueur hors tout	Lunghezza carro tra i respingenti	Längd över buffertar	Długość wagonu ze zderzakami	Tamponlar arası uzunluğu	23.240 mm	23.240 mm
Ladelänge	Loading length	Longueur utile	Lunghezza del piano di carico	Lastytans längd	Długość przestrzeni ładunkowej	Yükleme Boyu	29.978 mm	21.980 mm
Ladebreite	Loading width	Largueur utile	Larghezza del piano di carico	Lastytans bredd	Szerokość przestrzeni ładunkowej	Yükleme Eni	2.780 mm	2.780 mm
Ladefläche	Loading area	Superficie utile	Superficie di carico	Lastyta	Powierzchnia ładunkowa	Yükleme Alanı	61 m ²	61 m ²
Laderaum	Loading volume (cube)	Volume utile	Volume di carico	Lastvolym	Pojemność ładunkowa	Yükleme Hacmi	181 m ³	181 m ³
Schiebewandöffnung - Höhe	Access height when sliding doors fully opened/retracted	Ouverture des portes (hauteur)	Apertura parete scorrevole - Lunghezza	Skjutförröppning - höjd	Wysokość otworu po otwarciu drzwi przesuwnych	Kapı Ölçüleri - Yüksekliği	3.190 mm	3.190 mm
Schiebewandöffnung - Breite	Access width when sliding doors fully opened/retracted	Ouverture des portes (largeur)	Apertura parete scorrevole - Larghezza	Skjutförröppning - bredd	Szerokość otworu po otwarciu drzwi przesuwnych	Kapı Ölçüleri - Eni	10.816 mm	10.822 mm
Fußbodenhöhe über Schienenoberkante	Height of wagon floor over rail	Hauteur du plancher au-dessus du rail	Altezza del piano di carico dal piano rotaia	Lastytans höjd över rälsöverkant	Wysokość podłogi nad główką szyny	Platformun Raydan Yüksekliği	1.193 mm	1.192 mm
Zulässige Fußbodenbelastung	Maximum floor pressure allowed	Limite de charge du plancher	Limite di portata del pavimento	Högsta tillåtna golvbelastning	Dopuszczalna obciążenie podłogi	Maksimum Taban taşıma kapasitesi	50 kN	50 kN
Eigengewicht	Tare weight	Tare	Tara	Egenvikt	Masa własna	Darası	ca. 28.500 kg	ca. 28.000 kg
Lastgrenze D	Payload D	Limite de charge sur ligne D	Limite di portata (Linee classe D)	Lastgräns D	Dopuszczalna masa brutto (klasa D)	Yükleme Sınırları (D Hatları)	ca. 61,5 t	ca. 62,0 t
Lastgrenze C	Payload C	Limite de charge sur ligne C	Limite di portata (Linee classe C)	Lastgräns C	Dopuszczalna masa brutto (klasa C)	Yükleme Sınırları (C Hatları)	ca. 51,5 t	ca. 52,0 t
Kleinster befahrbarer Gleisbogenhalbmesser	Minimum curve radius	Rayon minimum de passage en courbe	Raggio minimo di curvatura	Minsta kurvradie	Minimalny promień skrętu	En az Kurp Yarıçapı	35 m	35 m
Palettenkapazität - Euro-Paletten	Pallet capacity - Euro Pallets	Nombre de palettes européennes	Capacità di carico - Euro-palette	Pallkapacitet - Eur-Pallar	Ilość palet - europalety	Palet Kapasitesi (Adet) EUR	54 units	54 units
Palettenkapazität - Industriepaletten	Pallet capacity - Industrial Pallets	Nombre de palettes industrielles	Capacità di carico - Palette industriali	Pallkapacitet - industriepallar	Ilość palet - palety przemysłowe	Palet Kapasitesi (Adet) EUR3 ve Universal	42 units	42 units
Zusatzdaten	Extra information	Données complémentaires	Dati supplementari	Tilläggsdata	Informacje dodatkowe	Diğer Bilgiler		
Verzurrösen (seitlich)	Securing rings (on side)	Anneaux d'arrimage (latéraux)	Occhielli di ancoraggio (laterali)	Lastsäkringsöglor - (på sidorna)	Uchwyty do lin zabezpieczających ładunek (boczne)	Sabit kancalar - Yan Duvar	32 units	32 units
Palettenstellplätze	Pallets	Disposition des palettes	Posti pallet	Pallplatser	ilość miejsc na palety	Palet Kapasitesi		
Höhe über Fußboden	Height above floor	Hauteur au-dessus du plancher	Distanza pavimento da rotaia	Höjd över golv	Wysokość od podłoga	Platformun Raydan Yüksekliği		
Vorhandene Ladebreite im Wandbereich	Maximum width wall	Largeur utile disponible entre les parois	Larghezza di carico in corrispondenza delle pareti scorrevoli	Tillgänglig lastbredd mellan skjutförrar	Szerokość ładowna pomiędzy ścianami	Kullanılabilir Yükleme Eni - Duvar bölümü		
Vorhandene Ladebreite im Säulenbereich	Maximum width pillar	Largeur utile disponible entre les montants	Larghezza di carico in corrispondenza dei montanti	Tillgänglig lastbredd vid mittportal	Szerokość ładowna pomiędzy słupkami	Kullanılabilir Yükleme Eni - Kolon bölümü		

Habiins-8/5, Habiins-12

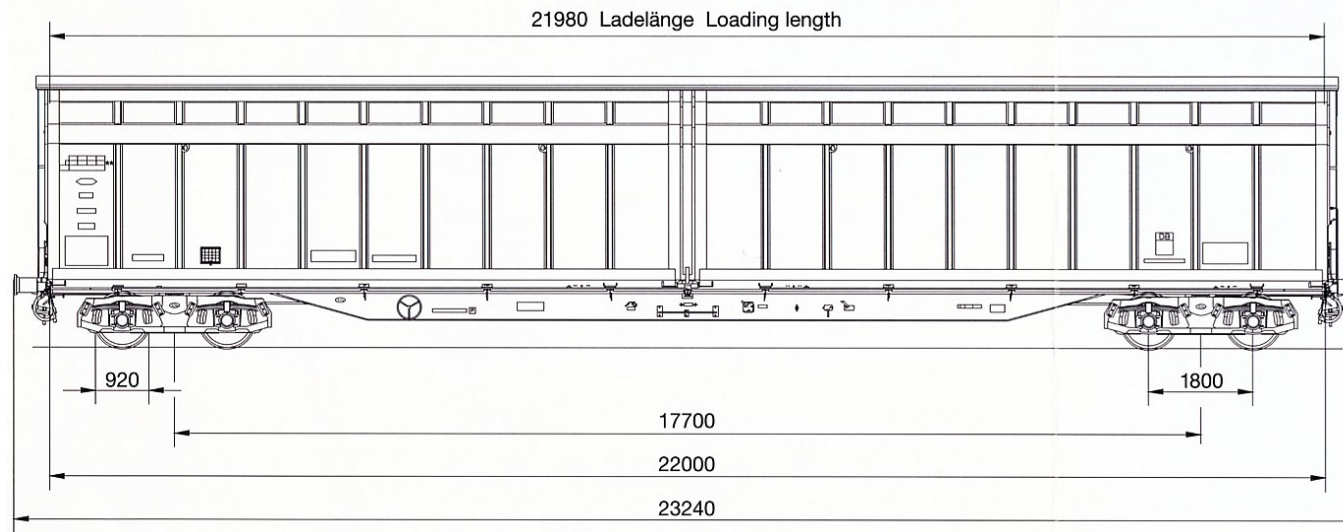

Habiins-8/5

					A	B	C	D		
S		36,0 t	44,0 t	54,0 t	62,0 t	**				
120	00,0 t									

Habiins-12

					A	B	C	D		
S		36,5 t	44,5 t	54,5 t	62,5 t	**				
120	00,0 t									

Palettenstellplätze

54 EUR-Paletten (800 x 1200 mm)

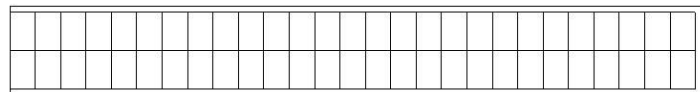

42 IND-Paletten (1000 x 1200 mm)

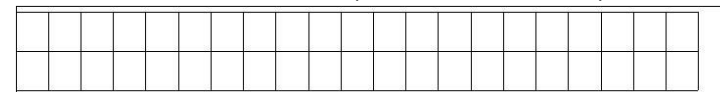

Habiins-8/5, Habiins-12

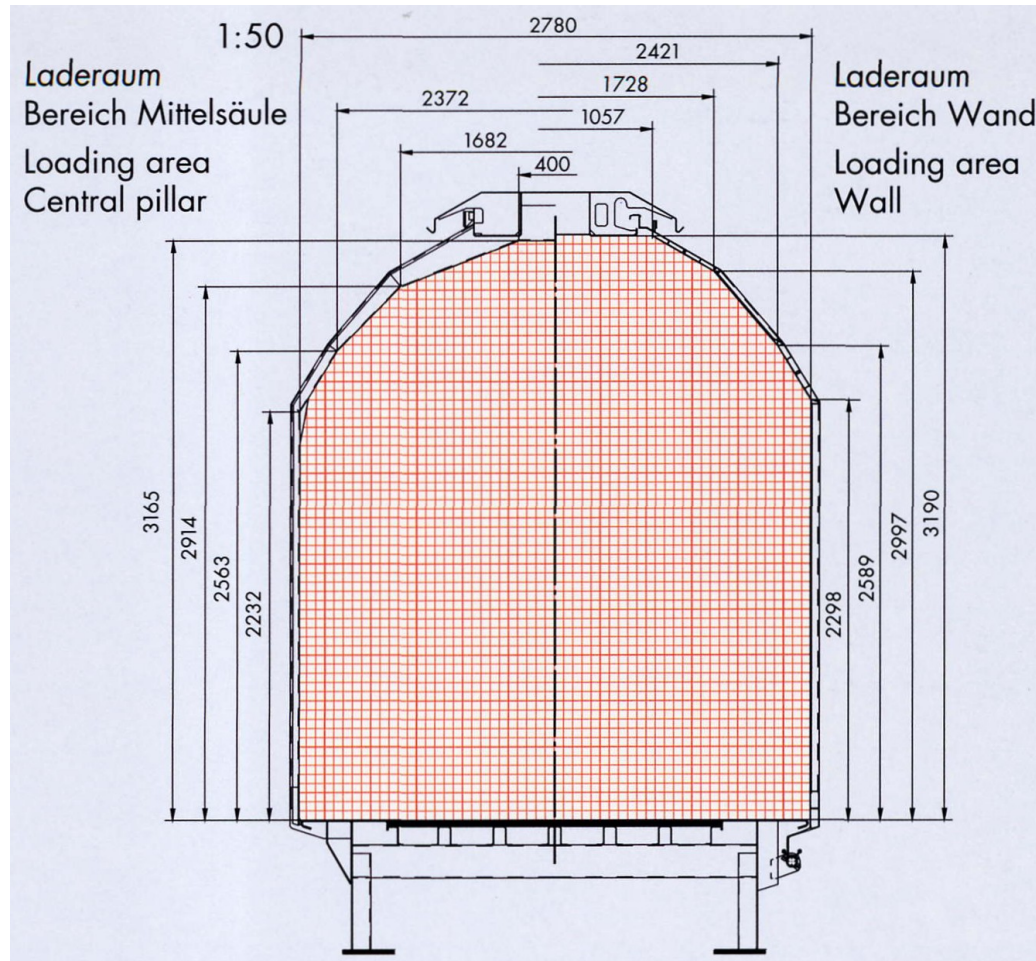

Höhe über Fußboden	Vorhandene Ladebreite im	
	Wandbereich	Säulenbereich
2055	2780	2780
2100	2780	2763
2150	2780	2744
2200	2780	2726
2250	2780	2707
2298	2780	2689
2350	2718	2635
2400	2655	2573
2450	2593	2511
2500	2531	2449
2550	2470	2380
2600	2403	2299
2650	2318	2200
2700	2233	2102
2750	2147	2004
2800	2062	1906
2850	1977	1808
2900	1891	1710
2914	1867	1682
2950	1806	1498
3000	1722	1243
3050	1542	978
3100	1369	732
3165	1143	400
3190	1057	0